

[I] Problems (1)-(3): Choose the correct answers (Multiple Choices)(複選題)

(1) Consider the ordinary differential equation: (5%)

$$\frac{dy}{dx} = -\frac{3xy + y^2}{x^2 + xy}$$

- (a) The equation is a nonexact second order ordinary differential equation.
- (b) The equation has an x -dependent integrating factor.
- (c) The equation has a y -dependent integrating factor.
- (d) The equation has an xy -dependent integrating factor.
- (e) All the above choices are incorrect.

(2) Consider the ordinary differential equation: (5%)

$$\frac{d^3y}{dx^3} - 4\frac{d^2y}{dx^2} + \frac{dy}{dx} + 6y = 0$$

- (a) The equation is a 3rd order nonlinear homogeneous ordinary differential equation.
- (b) If at $x = 0$, $y = 1$, $dy/dx = 2$, & $d^2y/dx^2 = 4$, then $(y)(dy/dx) = 2e^{4x}$.
- (c) If at $x = 0$, $y = 1$, $dy/dx = 3$, & $d^2y/dx^2 = 9$, then $(y)(dy/dx) = 3e^{3x}$.
- (d) If at $x = 0$, $y = 1$, $dy/dx = 4$, & $d^2y/dx^2 = 16$, then $(y)(dy/dx) = 4e^{2x}$.
- (e) All the above choices are incorrect.

(3) Let $P = (2, 9, 8)$, $Q = (6, 4, -2)$, & $R = (7, 15, 7)$, unit: m, then (10%)

- (a) Vector $\overrightarrow{PQ} \perp$ vector \overrightarrow{PR} .
- (b) $90 \text{ m}^2 \leq$ the area of the triangle $PQR \leq 100 \text{ m}^2$.
- (c) $6 \text{ m} \leq$ the distance from point P to the direction line of vector $\overrightarrow{QR} \leq 7 \text{ m}$.
- (d) If point $S = (11, 10, -3)$, then $PQSR$ forms a rectangle.
- (e) All the above choices are incorrect.

[II] Problems (4)-(8): Choose the correct answer (Single Choice) (單選題)

Problems (4)-(6): For the partial differential equation (PDE)

$$A(x, y) \frac{\partial^2 u}{\partial x^2} + B(x, y) \frac{\partial^2 u}{\partial x \partial y} + C(x, y) \frac{\partial^2 u}{\partial y^2} = D(x, y)$$

- (4) The PDE is a (2%)
- (a) homogeneous linear first-order PDE
 - (b) homogeneous non-linear first-order PDE
 - (c) non-homogeneous linear first-order PDE
 - (d) non-homogeneous non-linear first-order PDE
 - (e) homogeneous linear second-order PDE
 - (f) homogeneous non-linear second-order PDE
 - (g) non-homogeneous linear second-order PDE
 - (h) non-homogeneous non-linear second-order PDE

- (5) The PDE is called an elliptic type PDE if (2%)
- | | |
|---------------------|---------------------|
| (a) $B^2 - AC > 0$ | (b) $B^2 - AC = 0$ |
| (c) $B^2 - AC < 0$ | (d) $B^2 - 4AC > 0$ |
| (e) $B^2 - 4AC = 0$ | (f) $B^2 - 4AC < 0$ |
| (g) $B^2 + AC > 0$ | (h) $B^2 + AC = 0$ |
| (i) $B^2 + AC < 0$ | |
- (6) Which of the following statements is correct? (2%)
- The elliptic type PDE has 2 real characteristics.
 - The elliptic type PDE has no real characteristics.
 - The parabolic type PDE has 2 real characteristics.
 - The parabolic type PDE has no real characteristics.
 - The hyperbolic type PDE has no real characteristics.
 - The elliptic type PDE has 1 real characteristic.
 - The hyperbolic type PDE has 1 real characteristic.

Problems (7)-(8): For the PDE

$$\frac{\partial^2 u}{\partial x^2} - 4x \frac{\partial^2 u}{\partial x \partial y} + 4x^2 \frac{\partial^2 u}{\partial y^2} = 2 \frac{\partial u}{\partial y}$$

- (7) Which of the following is an equation of characteristic of the PDE (3%)
- | | |
|------------------------|-------------------------|
| (a) $y = 2x + C$ | (b) $y = -2x + C$ |
| (c) $y = x^2 + C$ | (d) $y = -x^2 + C$ |
| (e) $y = x^2 + 2x + C$ | (f) $y = -x^2 + 2x + C$ |
| (g) $y = x^2 - 2x + C$ | (h) $y = -x^2 - 2x + C$ |
- (8) The general solution of the PDE is (3%)
- $u = f(x^2 + y) + g(x + y)$
 - $u = f(x + y^2) + g(x + y)$
 - $u = f(x^2 + y) + x g(x + y)$
 - $u = f(x + y^2) + x g(x + y)$
 - $u = x f(x^2 + y) + g(x + y)$
 - $u = x f(x + y^2) + g(x + y)$
 - $u = x f(x^2 + y) + g(x^2 + y)$
 - $u = x f(x + y^2) + g(x + y^2)$
 - $u = x f(x^2 + y) + g(x + y^2)$
 - $u = f(x + y) + g(x - y)$
 - $u = f(x^2 + y) + g(x^2 - y)$

[III] Problems (9)-(18): True or False (是非題) (20%)

The following true/false question problems considers a dynamic system describes by the differential equation $Q(D)y(t) = P(D)f(t)$. With D denoting the differential operator, $Q(D)$ and $P(D)$ are defined as:

$$Q(D) = D^n + a_{n-1} D^{n-1} + \dots + a_1 D + a_0$$

$$P(D) = b_m D^m + b_{m-1} D^{m-1} + \dots + b_1 D + b_0$$

There are several ways to represent the response of this system as the sum of two components. For example, we can have

Total response = zero-input response + zero-state response
 = natural response + forced response
 = transient response + steady-state response

- (9) The zero-input component is the system response with the input $f(t) = 0$. In contrast, the zero-state component is the system response to the external input $f(t)$. Therefore, these two components are independent of each other.
- (10) The zero-input component is actually the homogeneous solution of the differential equation.
- (11) Mathematically, the zero-state component can always be determined by the method of undetermined coefficients.
- (12) One can use the Laplace transform to find the zero-state response by assuming that $y(0) = dy(0)/dt = \dots = d^{n-1}y(0)/d^{n-1}t = 0$.
- (13) By assuming that $y(0) = dy(0)/dt = \dots = d^{n-1}y(0)/d^{n-1}t = 0$, the Laplace transform of the differential equation can be represented as $Q(S)Y(s) = P(S)F(S)$. If $f(t)$ is the impulse function, we will have $Y(s) = P(S)/Q(S)$ since $F(s) = 1$.
- (14) By defining transfer function as $H(s) = P(S)/Q(S)$, we find that the transfer function is actually the Laplace transform of the impulse response of the system. By replacing S with λ , the denominator of the transfer function can be used to set up the characteristic equation for the ODE under consideration. In particular, this characteristic equation is $Q(\lambda) = 0$.
- (15) By assuming the roots of $Q(\lambda) = 0$ to be $\lambda_1, \lambda_2, \dots, \lambda_n$, the exponentials $e^{\lambda_i t}$ are called the characteristic modes (or simply modes) of the system, the natural response is then defined as the sum of all the mode terms of the total system response whereas the remaining part of the total system response is called the forced response. According to this definition, the forced response is actually the nonhomogenous solution of the ODE.
- (16) Since the zero-state response is the result of the application of $f(t)$, the zero-state response will not contain any characteristic mode terms.
- (17) The steady-state response is the response of the system as the time goes to infinity. The remaining portion of the total system response is then defined as

the transient response. By assuming the real part of the roots of $Q(\lambda) = 0$ are all negative, then we can conclude that the steady-state response has to be the result of $f(t)$.

- (18) The Laplace transform can be used to determine the steady-state and transient responses simultaneously.

- [IV] Use the method of separation of variables to solve the PDE (8%)

$$\frac{\partial^2 \theta(x,t)}{\partial x^2} = \frac{1}{a^2} \frac{\partial^2 \theta(x,t)}{\partial t^2} \quad \text{where } a \text{ is a constant.}$$

The boundary conditions are

- (i) $\theta(0,t) = 0$
 (ii) $\theta(l,t) = 0$

The initial conditions are **not** given, so you **do not** have to determine the final two unknown constants.

- [V] Find the residue at $z = 0$ of the function (A) $\frac{\cot z}{z^4}$, (B) $\frac{\sinh z}{z^4(1-z^2)}$. (10%)

- [VI] Evaluate the improper integral of $\int_{-\infty}^{\infty} \frac{x^3 \sin ax}{x^4 + 4} dx$ ($a > 0$). (10%)

- [VII] (A) A box function, $b(x)$ is as following: (5%)

$$b(x) = \begin{cases} 1, & |x| \leq 1/2 \\ 0, & \text{otherwise} \end{cases}$$

Please find the Fourier transform, $B(\nu)$, of $b(x)$, where ν is frequency measured in Hertz (cycles per second).

- (B) The convolution of $b(x)$ with itself is $t(x)$. Find the Fourier transform, $T(\nu)$, of $t(x)$. (5%)

- [VIII] The complex form of the Fourier series is: (10%)

$$f(x) = \sum_{k=-\infty}^{+\infty} c_k e^{i2\pi kx}$$

where c_k is a complex number and $c_k = c_{-k}^*$. Prove that the complex

coefficient, c_k , encodes the amplitude and phase coefficients, A_k and ϕ_k , in the alternative form:

$$f(x) = \sum_{k=0}^{+\infty} A_k \cos(2\pi kx - \phi_k)$$

- For a given pressure rise a gas turbine compressor would require a much greater work input per unit of mass flow than would the pump of a vapor power plant. Why? Use back work ratio to explain why we usually prefer to use Rankine cycle rather than use Brayton cycle in generating electrical power. 5%
- Consider two geothermal wells whose energy contents are estimated to be the same. Will the exergies of these wells necessarily be the same? Explain. 5%
- Please explain how to obtain the latent heat of a pure substance by measuring the properties: temperature, pressure, and specific volume and using their P-T curves at saturated states. You can use Clapeyron equation to explain it. 5%
- For a polytropic process $pv^n = \text{constant}$, sketch a p-v diagram and plot the compressing processes with $n=0, 1, 1.5, \infty$ from v_1 to v_2 on this diagram. Explain the meanings of each process with the different n values. Derive the work done per unit mass by these processes too. 15%
- When applying the energy balance to a reacting system, why is it essential that the enthalpies of each reactant and product be evaluated relative to a common datum? 5%
- The p-v-T relation for a certain gas is represented closely by

$$v = \frac{RT}{P} + B - \frac{A}{RT}$$

where R is the gas constant and A and B are constants. Determine expressions for the changes in specific enthalpy, internal energy, and entropy, $[h(p_2, T) - h(p_1, T)]$, $[u(p_2, T) - u(p_1, T)]$, $[s(p_2, T) - s(p_1, T)]$, respectively. 15%

- Consider a wall heated by convection on one side and cooled by convection on the other side. Show that the heat-transfer rate through the wall is

$$q = \frac{T_1 - T_2}{1/h_1A + \Delta x/kA + 1/h_2A}$$

where T_1 and T_2 are the fluid temperatures on each side of the wall and h_1 and h_2 are the corresponding heat-transfer coefficients. (15%)

- Find the heat transfer per unit area through the composite wall sketched. Assume one-dimensional heat flow. (20%)

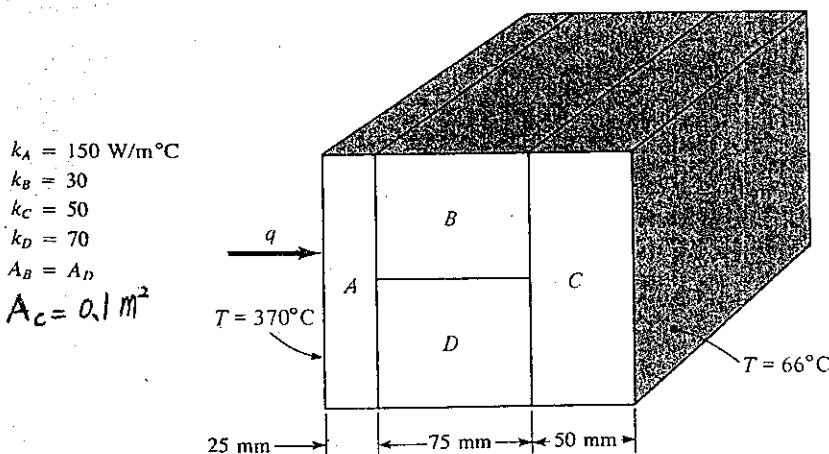

- Please explain the differences between (a) Carnot Cycle, (b) Rankine Cycle, and (c) Brayton Cycle by T-S and P-V curves of cycles. Why Carnot Cycle has the highest "efficiency"? (15%)

1. 請說明下列兩個流體常數的物理意義 (a) Reynolds number (b) Knudsen number (10 %)
2. 有一高度為 H 半徑為 R 之圓形汽油桶盛滿水，今將其下方開一半徑為 r 之洩水圓孔，請導出當液面由滿水位降至高度 h 時，所需之時間。(10 %)
3. For a fully developed pipe flow, SAE 10W oil at 20°C flows at $1.1\text{ m}^3/\text{h}$ through a horizontal pipe with $d = 2\text{ cm}$ and $L = 12\text{ m}$. Find (a) the average velocity, (b) the pressure drop, and (c) the power required. For SAE 10W oil, $\rho = 870\text{ Kg/m}^3$, $\mu = 0.104\text{ Kg/m}\cdot\text{s}$ (10 %)
4. Bernoulli's equation 為一能量守恆公式，請由 potential energy, kinetic energy 及 flow work 之守恆，導出 Bernoulli's equation 之基本式 (neglect the kinetic energy correction factor)。
 $(gz + \frac{V^2}{2} + \frac{p}{\rho} = \text{constant})$ 並請說明上列 Bernoulli's equation 成立之條件。其中 V : velocity, p : pressure, ρ : density (10 %)
5. A high-speed Indi-race-car with $M = 2000\text{ kg}$, C_D (風阻係數) $= 0.3$, and A (截面積) $= 1\text{ m}^2$ deploys a 2-m (diameter) parachute ($C_{Dp} = 1.2$) to slow down from an initial velocity of 100 m/s (as figure). Assuming constant C_D , brakes free, and no rolling resistance, calculate the distance and velocity of the car after 100 s. Assume $\rho_{\text{air}} = 1.2\text{ kg/m}^3$, and neglect interference between the wake of the car and the parachute. (10 %)

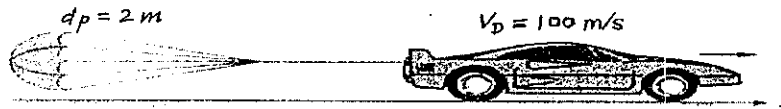

6. For a laminar flow, the velocity distribution in a pipe is a parabolic pattern. (as shown in the figure) Please draw the velocity distribution of a turbulent flow in a pipe and explain why the flow pattern is like that. (5 %)

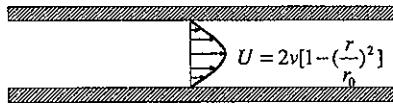

7. (15%) (a) Derive the continuity equation, $\frac{\partial u}{\partial x} + \frac{\partial v}{\partial y} = 0$, for a two-dimensional, steady incompressible flow. u and v are velocity components of the fluid in the x - and y -directions, respectively. Hint: consider the mass conservation of a control volume ($dx\ dy \cdot 1$) within the flow.
 (b) Derive the energy equation $u \frac{\partial T}{\partial x} + v \frac{\partial T}{\partial y} = \alpha (\frac{\partial^2 T}{\partial x^2} + \frac{\partial^2 T}{\partial y^2})$, for a steady thermal boundary layer flow. Assume that viscous dissipation is neglected and all physical properties are temperature-independent. α is thermal diffusivity. Hint: consider the net rate of conduction and convection through the surfaces of a control volume ($dx\ dy \cdot 1$).
8. (15%) For a fluid flow over a heated circular cylinder, the convection heat transfer coefficient (h_c) is dependent on the free stream velocity (U) of the fluid, the diameter of the cylinder (D), and physical properties (ρ, κ, μ, c_p) of the fluid, where ρ, κ, μ , and c_p are respectively the density, thermal conductivity, viscosity and specific heat at constant pressure of the fluid. Namely, $h_c = \text{fun}(U, D, \rho, \kappa, \mu, c_p)$
 (a) What are the basic (primary) dimensions in the above dimensional equation?
 (b) How many dimensionless groups can be formed if we want to nondimensionize the equation?
 (c) Determine the nondimensional groups, i.e. write the h_c -equation in dimensionless form
9. (15%) (a) Draw the temperature and velocity profiles in natural convection over a heated vertical plate.
 (b) What physical quantities are related to the natural convection problem?
 (c) What dimensionless groups (numbers) are important in the natural convection problem? (if you answer dimensionless numbers; please give their definitions)

1. The toggle clamp is subjected to a force F at the handle. Determine the vertical clamping force acting at E . (20%)

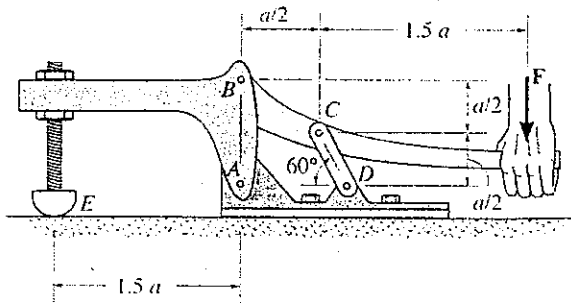

2. The coefficient of static friction between the drum and brake bar is $\mu_s = 0.4$. If the moment $M = 35$ N·m, determine the smallest force P that can be applied to the brake bar in order to prevent the drum from rotating. Also determine the horizontal and vertical components of reaction at pin O . Neglect the weight and thickness of the brake. The drum has a mass of 25 kg. (20%)

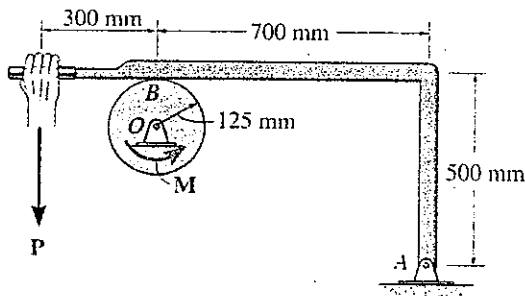

3. The 6-lb slender rod AB is originally at rest, suspended in the vertical position. A 1-lb ball is thrown at the rod with a velocity $v = 50$ ft/s and strikes the rod at C . Determine the angular velocity of the rod just after the impact. Take $e = 0.8$ and $d = 2$ ft. (20%)

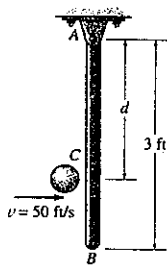

4. The rod assembly has a weight of 10 lb/ft. It is supported at B by a smooth journal bearing, which develops x and y force reactions, and at A by a smooth thrust bearing, which develops x , y , and z force reactions. If a 50-lb ft torque is applied along rid AB, determine the components of reaction at the bearings when the assembly has an angular velocity $\omega = 10 \text{ rad/s}$ at the instant shown. (20%)

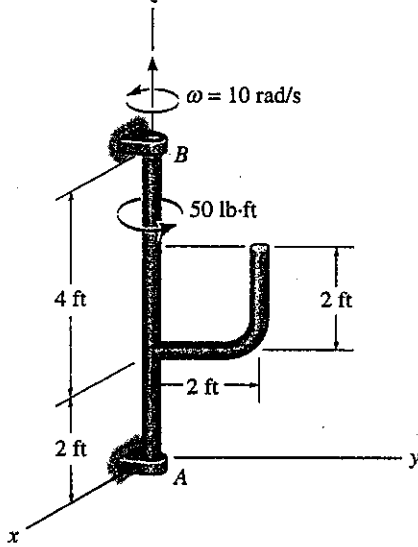

5. Force $f(t)$ is applied to the block with mass M in the following Figure. Find the equations of motion for the system. B is the coefficient of friction. (20%)

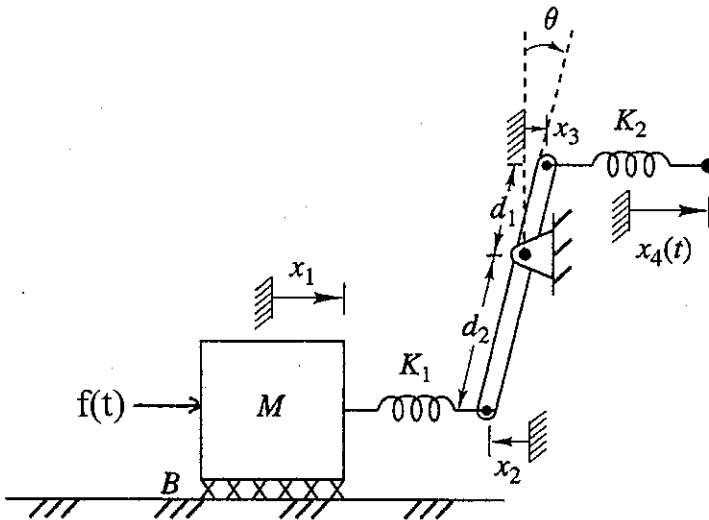

1. Explain the terms briefly: linear, elastic, isotropic, homogeneous, superposition. (10%)

2. The assembly has the diameters and material make-up indicated *right*. If it fits securely between its fixed supports when the temperature is $T_1 = 70^\circ F$, determine the average normal stress in each material when the temperature reaches $T_2 = 110^\circ F$. The coefficients of thermal expansion are:
 $\alpha_{Al} = 12.8 \times 10^{-6} / ^\circ F$, $\alpha_{Br} = 9.60 \times 10^{-6} / ^\circ F$,
 $\alpha_{St} = 9.60 \times 10^{-6} / ^\circ F$. (15%)

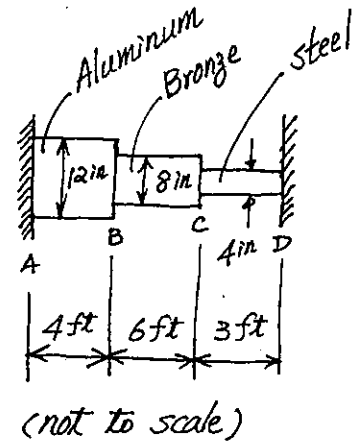

3. Let the state of stress at a point be given by $\sigma_x = 20$, $\sigma_y = 40$, $\sigma_z = -20$, $\tau_{yz} = 20$, $\tau_{zx} = -60$, $\tau_{xy} = -40$ MPa, and the material with normal yielding and shear yielding stresses, $\sigma_y = 90$ MPa, $\tau_y = 60$ MPa. Please determine (a) the three principal stresses, (10%) (b) the maximum shear stress, (5%) (c) tell that the material is whether failed due to the state of stress by three failure criteria, such as von Mises, Tresca, and maximum principal stress criterion. (10%)

4. Draw the conventional and true stress-strain diagrams for ductile material (not to scale) and name the related regions and stresses in the diagrams by English. (25%)

5. Draw the shear and moment diagrams for the beam shown on the right. Please note that you have to draw the free-body-diagrams, set up the equilibrium equations, solve for the equation of shear and moment, and draw the shear and moment diagrams. (25%)

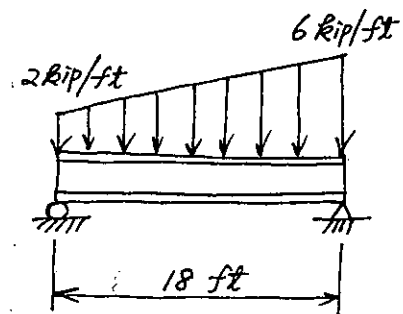

- (1). (30%) Please describe the following terminologies or items in detail (You need to make examples to explain.):
- Dominant poles
 - Pole-zero cancellations
 - System type
 - Relationship between impulse response and transfer function
 - Linearization of nonlinear system
 - State-feedback control with eigenvalue assignments
- (2). (20%) Please answer the following questions:
- Why PD controller could increase the system relative stability, and also the behavior of PD controller is likely as a high-pass filter? Meanwhile, please make an example.
 - Why PI controller could improve the system steady-state error, and also the behavior of PI controller is likely as a low-pass filter? Meanwhile, please make an example.
- (3). (15%) Consider a unit feedback control system as shown below, where $G(s)$ denotes the input-output relationship of a plant to be controlled. To design a proper controller $C(s)$, the transfer function $G(s)$ often needs to be known beforehand. However, the $G(s)$ is always an approximate representation of the real plant. There must exist some hidden poles or zeros in $G(s)$. Should one consider these hidden poles or zeros in the process of controller design? What are the effects on control performance when these poles or zeros are ignored? Please answer the questions as much as you can.

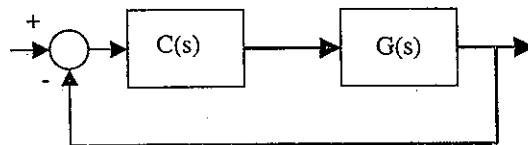

- (4). (14%) Consider a unit feedback control system as shown above. It is desired that the phase and gain margins of the control system are larger than 50° and 6dB, respectively. The steady-state error will go to zero when the reference input is a step function. Besides, the bandwidth of the closed-loop system is larger than ω_0 . Please draw a polar plot of $G(s)C(s)$ that can satisfy the above requirements. Please discuss your plot in details.

(5). (21%) It is given the Bode diagrams of three dynamic systems as shown below. Please estimate the transfer functions of these systems from the diagrams. In addition, please write down the reasons of your estimations.

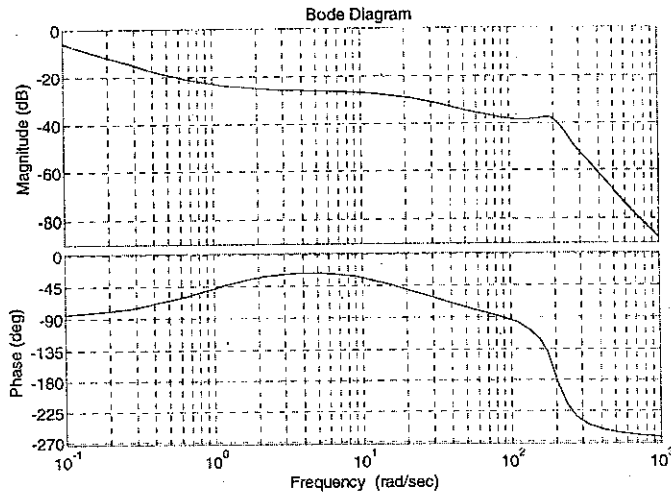

(a)

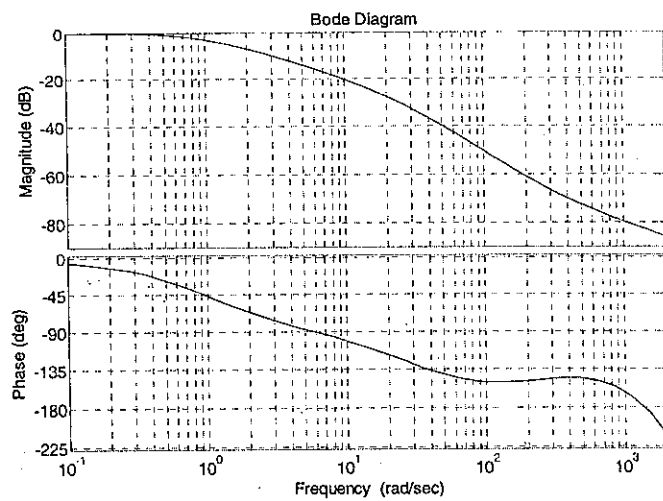

(b)

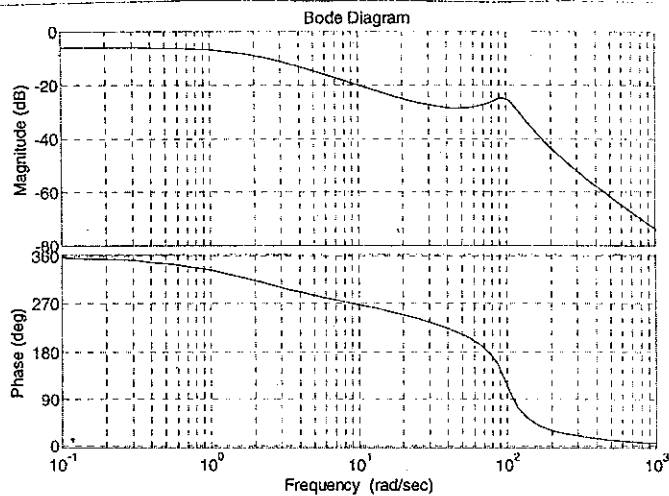

(c)

Problem 1. Fill in the blank with the proper word (於答案卷作答，中英皆可)

1. A vibratory system consists of a spring, damping, and _____. (2%)
2. When acceleration is proportional to the displacement and directed towards the mean position, the motion is called _____ harmonic. (3%)
3. Systems with an infinite number of degrees of freedom are called _____ or _____ systems. (6%)
4. If no energy is lost or dissipated in friction or other resistance during oscillation, the vibration is known as _____ vibration which represents interchange of _____ and _____ energies. (9%)
5. If the vibration of a system is linear, the principle of _____ holds. And if a system vibrates due to initial disturbance only, it is called _____ vibration. (6%)
6. _____ denotes the coincidence of the frequency of external excitation with a natural frequency of the system. (3%)
7. For free vibration of 1-DOF systems, the damping force in Coulomb damping is given by _____. (3%)
8. The vibration amplitude reduces _____ with Coulomb damping, whereas it reduces _____ with viscous damping. (6%)
9. In a 1-DOF free viscous damped system, any two successive peaks of displacements of the system, separately by a cycle, can be used to find the _____ decrement. (3%)
10. The response of a dynamic system to suddenly applied nonperiodic excitations is called _____ response. (3%)
11. In a 1-DOF undamped linear forced system, the phenomenon of _____ can occur when the forcing frequency is close to the natural frequency of the system. (3%)
12. In self-excited systems, the _____ itself produces the exciting force. (3%)

Problem 2. State in English Sir Isaac Newton's three laws of motion. (4% each, 12% in total.)

Problem 3. What are instant centers of velocity? Think of an example that you can use to demonstrate the usage of instant centers. (6% each, 12% in total, and you can write your answer in Chinese now.)

Problem 4. A planetary gear train is to be used in a clockwork to relate the motions of the hands. According to the design, the minute hand is fixed to the sun gear, and the hour hand is attached to the carrier connecting the sun and the planet gears. The ring gear is fixed. Now, what could the gear ratios, $N_{\text{planet}}/N_{\text{sun}}$ and $N_{\text{ring}}/N_{\text{sun}}$, be for the hands of the clock to have proper motions? (12%)

Problem 5. The link lengths of a 4-bar linkage are prescribed as follows: $l_1=30$ cm, $l_2=50$ cm, $l_3=40$ cm, and $l_4=60$ cm. Link 1 is grounded and the angle between links 1 and 2 is currently 45° . We know that the input link 2 rotates counterclockwise with a constant angular velocity $\omega_2=10$ rad/sec. Now compute (1) the angular acceleration α_4 of link 4 at this moment, and (2) the instantaneous acceleration a_C of a point C located at the midpoint of link 3. (7% each, 14% in total. Work on only either of the two possible branch configurations.)

- (20%) If the potential function for a conservative two degrees of freedom system is $V = (6y^2 + 2x^2) J$, where x and y are given in meters, determine (a) the equilibrium position, and (b) investigate the stability at this position.
- (20%) As shown in Figure P2, the cable is subjected to a triangular loading. If the weight of the cable is neglected and the slope of the cable at point A is zero, L , h , and W_0 is constant. Determine (a) the equation of the AB curve $y=f(x)$, expressed in L , h , or W_0 , and (b) the maximum tension in the cable, expressed in L , h , or W_0 .

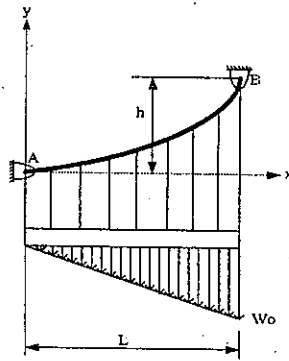

Figure P2

- (10%) As shown in Figure P3, two smooth balls are hung by long 100 mm rope, respectively, at point A and contact together at point B. Each ball with 20 mm in radius weighs 200 g, please find (a) tension in rope AC in Newton force, and (b) contact force at point B in Newton force.

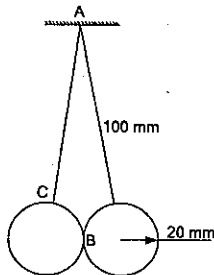

Figure P3

4. (20%) As shown in Figure P4, the cable AB keeps the 8-kg collar A in place on the smooth bar CD. The y axis points upward. What is the tension in the cable?

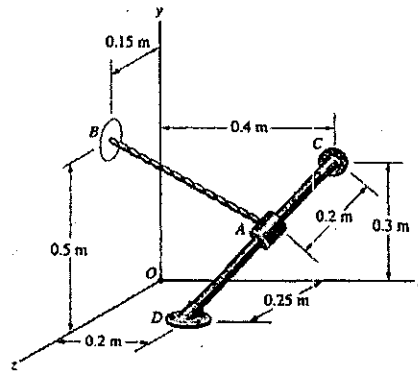

Figure P4

5. (20%) As shown in Figure P5, the coefficient of static friction between the 20-lb bar and the floor is $\mu_s = 0.3$. Neglect friction between the bar and the wall.
- (a) If $\alpha = 20^\circ$, what is the magnitude of the friction force exerted on the bar by the floor?
- (b) What is the maximum value of α for which the bar will not slip?

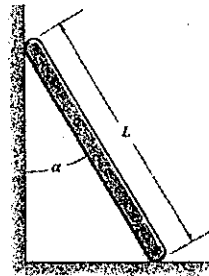

Figure P5

6. (10%) As shown in Figure P6, the 2-m long, 10-kg homogeneous bar is pinned at A and at the midpoint B to light collars that slide on a smooth bar. The spring attached at A is unstretched when $\alpha = 0^\circ$, and its constant is $k = 1.2 \text{ kN/m}$. List the equation of α when the bar is in equilibrium.

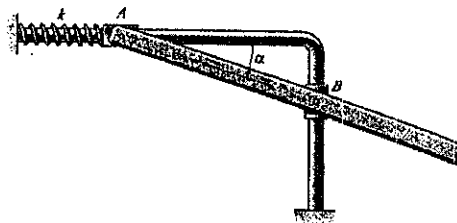

Figure P6